



400 Series

403D-15T

Compact Industrial and Construction Power

30 kW / 40.2 bhp @ 3000 rpm

The Perkins 400D range has been developed in consultation with our marketplace. This 1.5 litre, 3 cylinder, turbocharged engine is a new product to the 400 Series product line-up. The 403D-15T increases a customers choice and offers increased power with a minimal impact on package size. The 403D-15T also offers all the customer benefits they can experience from other products in the range.

Ultra-compact power

- Up to 30 kW from an engine envelope of 0.18 m³
- Coolant temperature of 112°C allows reduction in radiator size

Clean and quiet

- Noise levels have been kept to a minimum
- Subjective harshness has been carefully controlled making the engine sound even quieter

Durable power

- Product design and process improvements enhance both engine reliability and durability
- An improved governor and compliance testing delivering reliability with 6,000 hours durability
- A standard 2 year warranty demonstrates our confidence in durability and reliability

Low operating costs

- Approved for operation on biodiesel* concentrations of up to 20%
- Oil and filter changes are now set at 500 hours as standard
- Engine durability and reliability, the warranty offering, and ease of installation combine to drive down the cost of ownership

Product support

- Through an experienced global network of distributors and dealers, fully trained engine experts deliver total service support around the clock, 365 days a year. They have a comprehensive suite of web based tools at their fingertips, covering technical information, parts identification and ordering systems, all dedicated to maximising the productivity of your engine
- Perkins actively pursues product support excellence by insisting our distribution network invest in their territory to provide you with a consistent quality of support across the globe
- Throughout the entire life of a Perkins engine, we provide access to genuine OE specification parts giving 100% reassurance that you receive the very best in terms of quality for lowest possible cost... wherever your Perkins powered machine is operating in the world

Certified to Stage IIIA, Tier 4a (19-37 kW).

The 400 Series engine family continues to set new standards in the compact engine market. Developed alongside customers to fulfil their needs in the construction, materials handling, agricultural/turf, gen set and compressor markets, it is another class leading diesel range from Perkins.

Built to the most demanding standards, the 400D engines meet all the requirements of the off-highway emissions legislation for EC Stage IIIA/USA EPA Tier 3 and beyond.

Long 500 hour service intervals, a two year standard warranty, low noise and harshness, and a wide range of options make the 400 Series range the complete solution for compact power needs.

The 403D-15T is a very quiet 1.5 litre unit that delivers improved performance and reduced operating costs in a small, efficient package ideal for a range of off-highway applications.

Performance Data	Gross Intermittent (ISO/TR 14396)	Speed (rev/min)
Power Output (kW)	30.0	3000
Power Output (bhp)	40.2	3000
Peak Torque (Nm)	111.9	1800
Peak Torque (lbf ft)	82.5	1800

Power output for a run-in engine after 60 hours.

*Subject to conformance with ASTM D6751 and EN14214.

Photographs are for illustrative purposes only and may not reflect final specification.

All information in this document is substantially correct at time of printing and may be altered subsequently

Publication No. 1816/05/09 Produced in England ©2007 Perkins Engines Company Limited

400 Series

403D-15T

Engine Specification

- Cast iron engine block
- Flywheel and flywheel housing
- CTD fuel injection pump
- Spin on fuel filter
- Glow plug starting aid
- Lub oil sump
- Spin on lub oil filter
- Inlet manifold
- Cast iron exhaust manifold – side outlet
- Coolant pump belt driven
- Choice of cooling fans
- Starter motor 12 volt and 24 volt
- Alternator 12 volt and 24 volt
- ESOS
- Lub oil pressure switch
- Coolant temperature switch
- SAE A PTO
- Cold start to -30°C (aided)
- High and low fan position
- Electronic controlled governing as an option

General Data

Number of cylinders	3 in-line
Bore and stroke	84 x 90 mm
Displacement	1.496 litres (91 cu.in)
Aspiration	Turbocharged
Cycle	4 stroke
Combustion system	Indirect injection
Compression ratio	22.5:1
Rotation	Anti-clockwise viewed on flywheel
Cooling system	Liquid
Total lubrication capacity	6 litres
Total coolant capacity	2.4 litres
Dimensions	Length 572 mm Width 512 mm Height 643 mm
Dry weight	156.5 kg

Final weight and dimensions will depend on completed specification.

Option Groups

A selection of optional items is available to enable you to prepare a specification precisely matched to your needs.

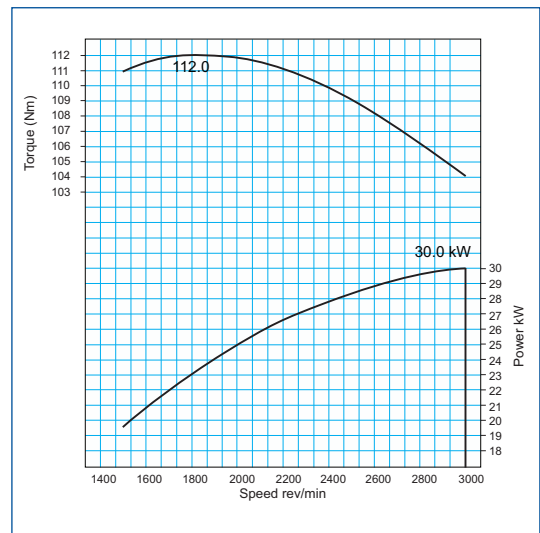
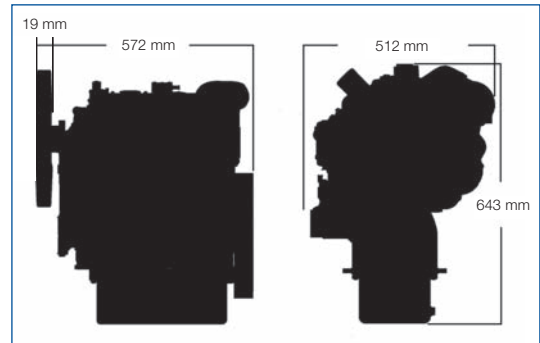

Lower speed ratings may not be read from this curve.



Perkins Engines Company Limited

Peterborough PE1 5NA
United Kingdom
Telephone +44 (0)1733 583000
Fax +44 (0)1733 582240
www.perkins.com

Distributed by